

DT4-B261

Flat bed double chain stitcher

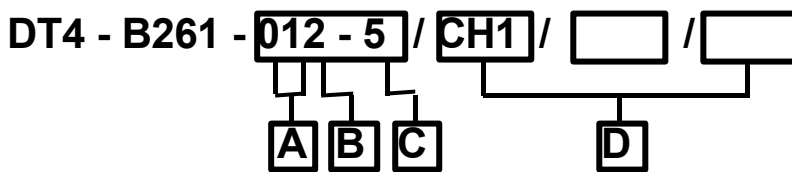

Specifications



A	Feed type
01	Uniform feed
0D	Differential feed
0M	Differential feed (For attaching pocket facing)

B	Specifications
2	Standard gauge for medium materials / gauge for lap seams
3	Gauge for heavy materials Lap seams (No level difference between right & left)
4	Gauge for heavy materials Lap seams (Level difference between right & left: 9 mm)
5	Gauge for heavy materials Lap seams (reverse) (No level difference between right & left)

D	Device
CH1	Pneumatic-type chain cutter
CH2	Vacuum-type chain cutter
PR1	Rear puller device

* -013 and -014 with PR1 specifications are available, but it can not be attached separately after purchase.

* PR1 can be attached to -015 as a special order.













* CH1 and CH2 can not be used with PR1.







* CH1 and CH2 can be attached to all machines which are not provided with PR1 at any time after purchase.

C	No. of needles / Needle gauge
0	Single needle
5	Flat twin needle 6.4 mm
6	Flat twin needle 7.2 mm
T	Vertical twin needle 0.4 mm
M	Three needle for attaching pocket facing 2.5 mm - 6.4 mm

* In addition to the above, the gauges for each specification are prepared as optional parts. Please refer to the gauge parts list.

Specifications

Sub-class	Application			No. of needle	Needle type (UY128GAS)
012-0	For plain stitching (Single needle, lower feed, medium materials) * For general sewing of medium materials such as the side of slacks.			1	SCHMETS #80 - #120 ORGAN #12 - #19
012-5	For sewing lap seams (Twin needle, lower feed, medium materials) * For sewing lap seams of medium materials such as the sides and seats of work clothes.			2	SCHMETS #80 - #120 ORGAN #12 - #19
012-T	For plain stitching (Tandem needle, lower feed, medium materials) * For general sewing of medium materials in places where extra strength is necessary, such as the seats of slacks.			2	SCHMETS #80 - #120 ORGAN #12 - #19
0D2-0	For plain stitching (Single needle, differential feed, medium materials) * For general sewing of stretch materials such as knitted wear.			1	SCHMETS #80 - #120 ORGAN #12 - #19
013-5	For sewing lap seams (Twin needle, lower feed, medium to heavy materials)			2	SCHMETS #120 - #140 ORGAN #19 - #22
013-6	* For sewing crotches in jeans, etc.				
013-5/RP1	For sewing lap seams (Twin needle, lower feed, medium to heavy materials)			2	SCHMETS #120 - #140 ORGAN #19 - #22
013-6/RP1	* For sewing crotches in jeans, etc.				
014-5	For sewing lap seams (Twin needle, lower feed, heavy materials)			2	SCHMETS #120 - #140 ORGAN #19 - #22
014-6	* For sewing crotches in jeans, etc.				
014-5/RP1	For sewing lap seams (Twin needle, lower feed, heavy to extra-heavy materials)			2	SCHMETS #120 - #140 ORGAN #19 - #22
014-6/RP1	* For sewing crotches in jeans, etc.				
015-5	For sewing lap seams (Reverse) (Twin needle, lower feed, medium to heavy materials)			2	SCHMETS #120 - #140 ORGAN #19 - #22
015-6	* For attaching risers to back panels of jeans, etc.)				
0M2-M	For attaching pocket Facing to pockets on slacks and jeans. (Triplet needle, differential feed, medium to heavy materials) * 3 row of double chain stitches with spreader thread.			3	SCHMETS #80 - #120 ORGAN #12 - #19

					
Needle gauge (mm)	No. of thread	Max. stitch length (mm)	Differential feed ratio	Height of presser foot (mm)	Max. sewing speed (rpm)
/	2	3.6	/	10	6,500
6.4	4	3.6	/	10	6,000
0.4	4	3.6	/	10	6,500
/	2	3.6	0.7 – 1.6 mm	10	6,000
6.4	4	4.2	/	10	5,000
7.2					
6.4	4	4.5	/	10	4,500
7.2					
6.4	4	4.2	/	10	5,000
7.2					
6.4	4	4.5	/	10	4,500
7.2					
6.4	4	4.2	/	10	5,000
7.2					
 A = 6.4 B = 2.5	7	3.6	0.7 – 1.2 mm	6	5,000

*1 -015 specification is suitable for hem stitching (double-folded) which is used for sewing jeans pocket mouth. However, the folder needs to be prepared separately.

Optional parts

The following optional parts are available for the DT4-B261.

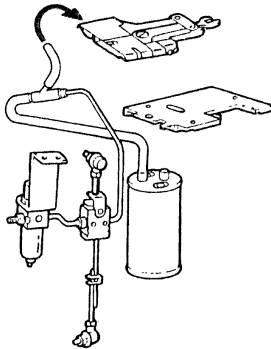
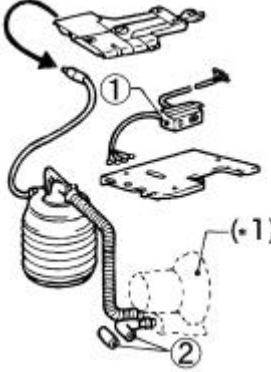
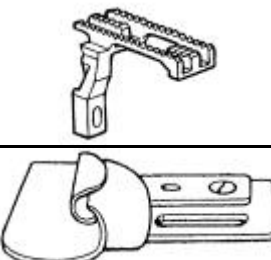
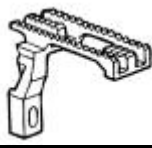
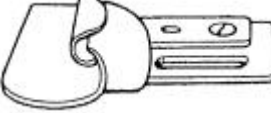
Part name	Part code	Sub-class
 <p><CH1> Chain cutter device set. (Air)</p>	S36510-102	-012 (*2) -0D2
	S47537-002	-013 (*3) -014 (*3) -015
	S47536-002	-0M2
 <p><CH2> Chain cutter device set. (Vacuum) * With power supply switch ① for blower and silencer ②.</p>	S13079-202	-012 (*2) -0D2
	S47539-002	-013 (*3) -014 (*3) -015
	S47538-002	-0M2
 <p><CH2> Chain cutter device set. (Vacuum) * Without power supply switch ① for blower and silencer ②. (If using the optional blower assembly (*1), please order this chain cutter device set.)</p>	S13080-102	-012 (*2) -0D2
	S47541-002	-013 (*3) -014 (*3) -015
	S47540-002	-0M2
 <p>Feed dog (For thin materials)</p>	S40564-001	-012-0
 <p>Lapper 1/4 M assembly</p>	151584-001	-012-5

(*1) Blower assembly (For <CH2>)

3-phase	200/220 V	50/60 Hz	0.09/0.12 kW	147979-301
3-phase	380V	50 Hz	0.09 kW	147979-202
3-phase	220/380 V	50 Hz	0.09 kW	147979-203
Single	220 V	50 Hz	0.09 kW	147979-205
Single	115 V	60 Hz	0.12 kW	147979-206
Single	240 V	50 Hz	0.09 kW	147979-207
3-phase	400/440 V	50 Hz	0.09 kW	147979-214

The blower power supply switch and silencer are provided with blower assembly.

(*2) When using the B261-012-0 with a chain installed, set the sewing speed to 6,000 rpm or less.

(*3) When using the B261-013 and -014 with a chain cutter installed, the formation of chaining-off stitches will become more difficult when the standard presser foot assembly is used. Because of this, you should follow the steps in either Solution 1 or Solution 2 as given below.

(Solution 2 is recommended for a more attractive chaining-off stitch formation.)

<Solution 1>

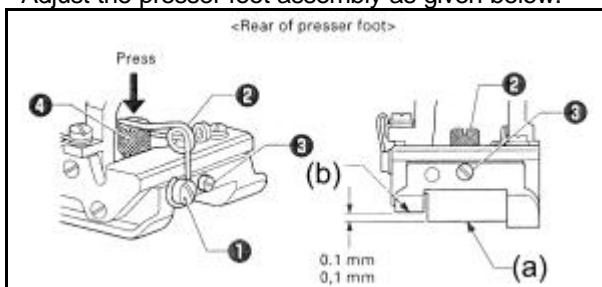

Adjust the presser foot assembly as given below.



- (1) Remove the Screw ① and remove the spring ②.
- (2) Loosen the set screw ③.
- (3) While loosening the thumb screw ④, push it from above until surface (a) is about 0.1 mm below surface (b). Then tighten the set screw ③.
- (4) Securely tighten the thumb screw ④.

<Solution 2>

Use the chaining-off stitch presser foot assembly.

Part name		Part code		Sub-class	
Feeding presser foot (For preventing seam slippage) 	Feeding presser foot set	Feeding presser foot	S40548-301	012-0	
		Presser bar spring	S18947-001		
		Presser bar stopper	S40539-001		
		4.37 bolt	154574-001		
		4.37 nut	102571-001		
		Bolt (x2)	117516-001		
		Washer (x2)	100645-003		
		Washer (x2)	140407-001		
Chaining-off stitch presser foot for heavy materials. * This presser foot provides better stitch formation performance for chaining-off stitches. 	Presser foot 1/4 KF assy. 6.4 mm, flat type	S48638-001	013-5		
	Presser foot 9/32 KF assy. 7.2 mm, flat type	S48641-001	013-6		
	Presser foot 1/4 KD assy. 6.4 mm, horizontally stepped (1.9 mm)	S48639-001	014-5		
	Presser foot 9/32 KD assy. 7.2 mm, horizontally stepped (1.9 mm)	S48642-001	014-6		
4.8 mm lap seam gauge	3/16 gauge set	Needle clamp 3/16 assy.	S47216-001	012-5 (*4)	
		Presser foot 3/16 assy.	S47219-001		
		Needle plate 3/16	S47218-001		
		Feed dog	S47221-001		
	Lapper 3/16 For thin materials	S49420-001			
Lapper 3/16 For medium materials	115834-001				
7.2 mm lap seam gauge (medium materials)	9/32 gauge set	Needle clamp 9/32 assy	S44880-001	012-5 (*4)	
		Presser foot 9/32 assy	S51434-001		
		Needle plate 9/32	S51433-001		
		Feed dog	S45092-001		
9.5 mm lap seam gauge (medium materials)	3/8 gauge set	Thread guide, needle bar	115904-001	012-5 (*4)	
		Needle clamp 3/8 assy	S45085-001		
		Presser foot 3/8 assy	S45090-001		
		Needle plate 3/8	S45087-001		
		Feed dog	S45092-001		
		Rear needle guard H (*5)	S40985-201		
		Front needle guard 3/8	S45089-001		
		Front cover	S47181-001		
		Sub-front cover	S47182-001		
		Screw, flat SM 3.57 (x2)	108960-002		
		Sub-cloth plate	S44876-001		
		Lapper 3/8 MH assy	S37818-001		

(*4) If changing the specifications based on specifications for other models, refer to the parts book for details on which parts need to be replaced.

(*5) For sewing machines which have the new type of rear needle guard H installed, it is not necessary to replace rear needle guard H.

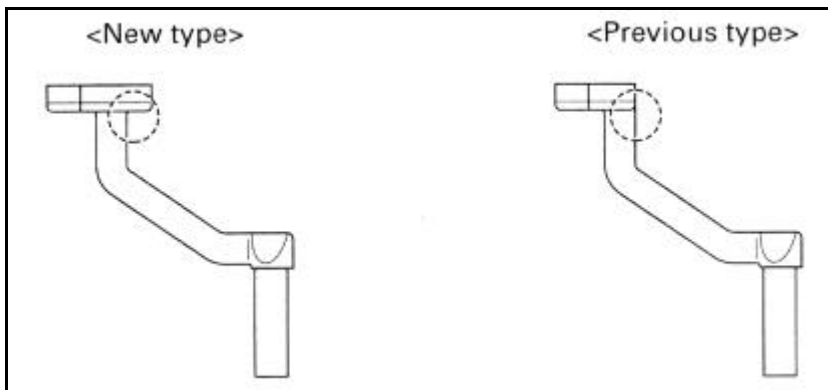

* The puller cannot be attached separately, so it is not available as an optional part.

Synchronizer

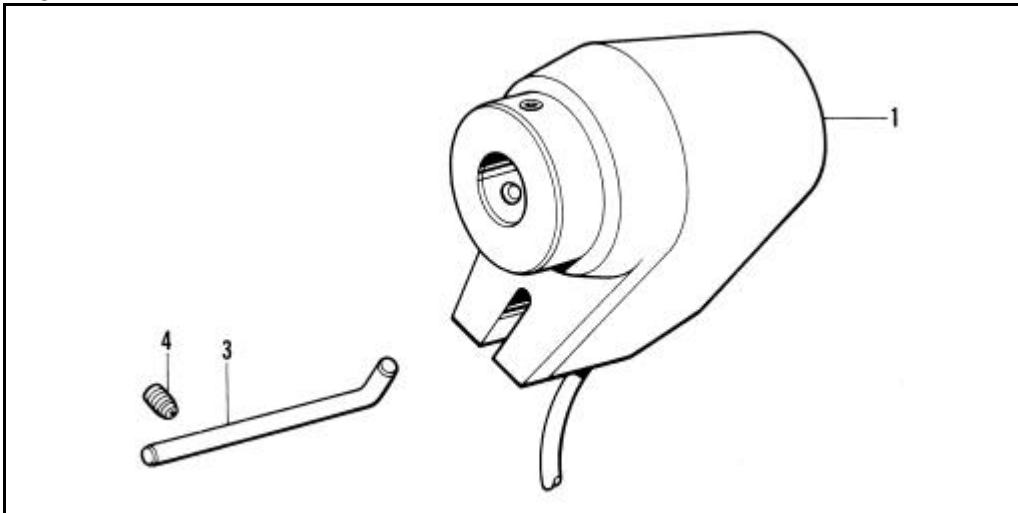

Ref. No.	Part name	Part code	Q'ty
1	Synchronizer #17-2	J80347-001	1
3	Synchronizer guide	S28963-001	1
4	Set screw, socket (CP) SM4.37	014680-622	1

* When using the synchronizer, use the motor and V belt listed below.

Motor

Single-phase	MD-601R
3-phase	MD-611R









V-belt

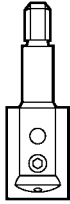
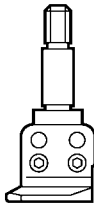
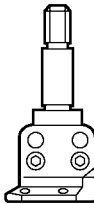
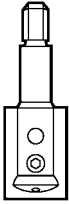
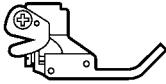
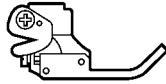
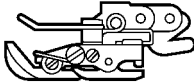
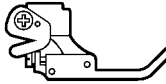
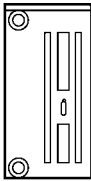
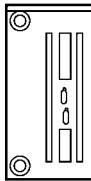
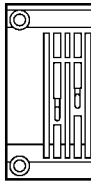
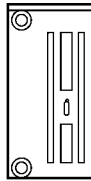
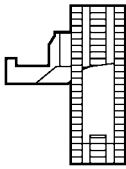
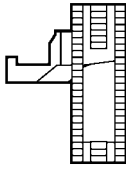
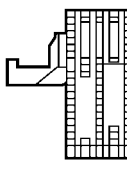
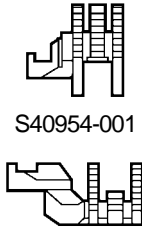
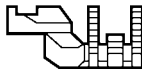
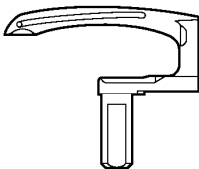

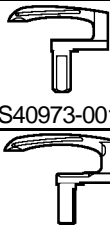

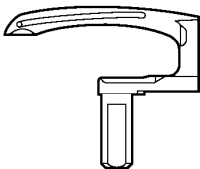

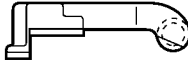



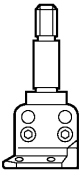
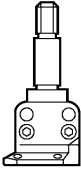
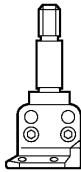
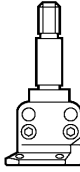
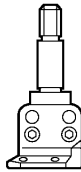
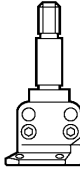
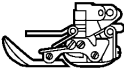



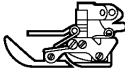
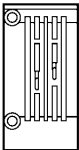
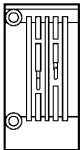
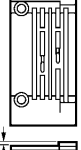
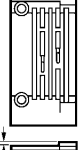
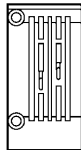
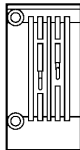
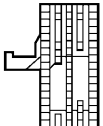
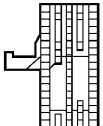
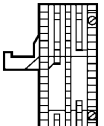
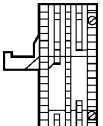
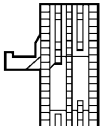
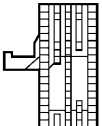







V-belt	M 38
--------	------

Lap seam folders

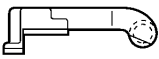
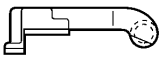
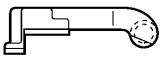
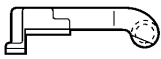
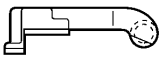
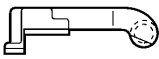









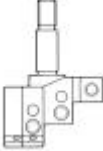
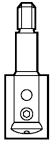
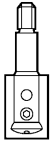
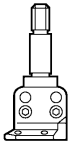
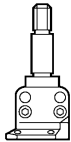

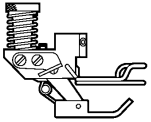
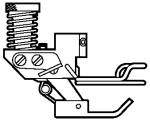
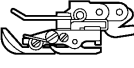
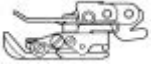
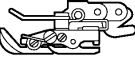

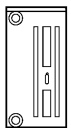
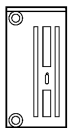
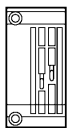

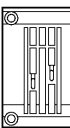
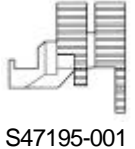
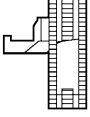
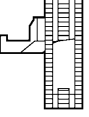
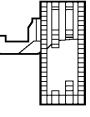
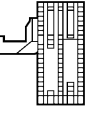
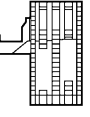





Material type	Needle gauge	Part name	Part code	Provided as a standard for:
Thin materials	4.8 mm	Lapper 3/16assy	115834-001	Option
	6.4 mm	Lapper 1/4 M assy	151584-001	Option
Medium materials	4.8 mm	Lapper 3/16 M assy	S49420-001	Option
	6.4 mm	Lapper 1/4 assy	113880-001	012-5
	7.2 mm			
	9.5 mm	Lapper 3/8 MHassy	S37818-001	Option
Heavy materials	6.4 mm	Lapper 1/4 XHassy	S44912-000	013-5, 013-5/RP1 013-6, 013-6/RP1 014-5, 014-5/RP1 014-6, 014-6/RP1
	7.2 mm			
Heavy materials For sewing lap seams (Reverse)	6.4 mm	Lapper 1/4 XHG assy	S48630-001	015-5, 015-5/RP1 015-6, 015-6/RP1
	7.2 mm			

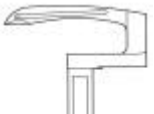



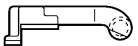
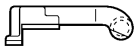
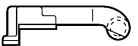





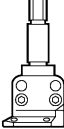
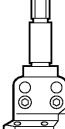
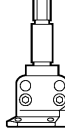
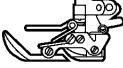
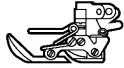

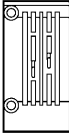
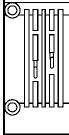
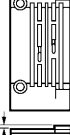

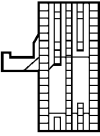
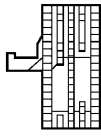
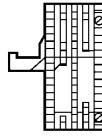
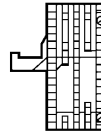

GAUGE PARTS LIST

Specifications	012-0	012-T	012-5	0D2-0
Label	S28933-003	S28933-004	S28933-005	S28933-006
Application	Plain stitching	Plain stitching	Binding stitching	Plain stitching
No. of needles	1	2	2	1
Needle spacing (mm)	-	0.4	6.4	-
Needle clamp assembly	 S17480-201	 S40962-001	 S40987-101	 S17480-201
Presser foot assembly	 S40541-101	 S40969-101	 S40990-201	 S40952-101
Needle plate	 S40538-001	 S40964-001	 S40989-001	 S40538-001
Feed dog	 S40565-001	 S40972-001	 S40995-001	 S40954-001  S40955-001
Looper	 S40569-001	 S40973-001  S40974-001	 S40973-001  S40974-001	 S40569-001
Needle guard	 S08756-001	 S40967-001	 S40985-201  S40986-101	 S08756-001

013-5	013-6	014-5	014-6	015-5	015-6
S28933-008	S28933-009	S28933-010	S28933-011	S28933-013	S28933-014
Heavy materials	Heavy materials	Heavy materials	Heavy materials	Heavy materials	Heavy materials
2	2	2	2	2	2
6.4	7.2	6.4	7.2	6.4	7.2
					
S40987-101	S44880-001	S40987-101	S44880-001	S40987-101	S44880-001
					
S44888-001	S44892-001	S44891-001	S44894-001	S48633-001	S48636-001
		 1.9	 1.9		
S44883-001	S44885-001	S44884-001	S44886-001	S44883-001	S44885-001
					
S44904-001	S44904-001	S44901-001	S44901-001	S44904-001	S44904-001
					
S40973-001	S40973-001	S40973-001	S40973-001	S40973-001	S40973-001
					
S40974-001	S40974-001	S40974-001	S40974-001	S40974-001	S40974-001
					
S40985-201	S40985-201	S40985-201	S40985-201	S40985-201	S40985-201
					
S40986-101	S40986-101	S40986-101	S40986-101	S40986-101	S40986-101

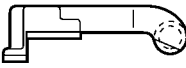
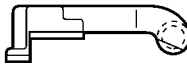
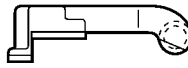
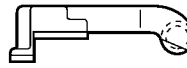
GAUGE PARTS LIST

Specifications	OM2-M	for 012-0	for 012-0	for 012-5	for 012-5	for 012-5
Label	S28933-012	Option	Option	Option	Option	Option
Application	Attaching medium pocket facing	Plain stitching (Thin W / feeding presser foot)	Plain stitching (Medium thick W / feeding presser foot)	Binding stitching	Binding stitching	Binding stitching
No. of needles	3	1	1	2	2	2
Needle spacing (mm)	2.5 – 6.4	-	-	4.8	7.2	9.5
Needle clamp assembly	 S47183-001	 S17480-201	 S17480-201	 S47216-001	 S44880-001	 S45085-001
Presser foot assembly	 S47187-101	 S40548-301	 S40548-301	 S47219-001	 S51434-001	 S45090-001
Needle plate	 S47185-001	 S40538-001	 S40538-001	 S47218-001	 S51433-001	 S45087-001
Feed dog	 S47195-001	 S40564-001 (Extra fine feed dog)	 S40565-001	 S47221-001	 S40995-001	 S45092-001
	 S47196-001					
Looper	 S47197-001	 S40569-001	 S40569-001	 S40973-001	 S40973-001	 S40973-001
	 S47198-001					
	 S47199-001					
Needle guard	 S47186-001	 S08756-001	 S08756-001	 S40985-201	 S40985-201	 S40985-201
	 S47204-101					
				 S40986-101	 S40986-101	 S45089-001

for 013-5 Option	for 013-6 Option	for 014-5 Option	for 014-6 Option
Heavy materials	Heavy materials	Heavy materials	Heavy materials
2	2	2	2
6.4	7.2	6.4	7.2
 S40987-101	 S44880-001	 S40987-101	 S44880-001
 S48638-001	 S48641-001	 S48639-001	 S48642-001
 S44883-001	 S44885-001	 1.9 S44884-001	 1.9 S44886-001
 S44904-001	 S44904-001	 S44901-001	 S44901-001
 S40973-001	 S40973-001	 S40973-001	 S40973-001
 S40974-001	 S40974-001	 S40974-001	 S40974-001
 S40985-201	 S40985-201	 S40985-201	 S40985-201
 S40986-101	 S40986-101	 S40986-101	 S40986-101